

# Hardware Development of a Transducer Array for Acoustic Levitation

## Levitating and Moving Particles Using Ultrasonic Waves

### Graduate



Dominic Schmech



Erik Löffler

**Definition of Task:** The scope of this project is to evaluate and implement a design for an ultrasonic transducer array that enables levitation and motion control of up to two particles. Levitation is achieved by controlling the phases of multiple transducers, resulting in standing waves that create trap points in 3D space. By changing the phases of the transducers, these trap points can be moved. This project was carried out in collaboration with another group that designed the algorithm to control the transducer array and developed an FPGA-based control system.

**Approach:** We decided to develop a prototype on a smaller scale first to test the design of key parts of the system. The prototype has an array size of 5x5 at the top and bottom. This resulted in reduced capabilities, but still provided enough flexibility for both groups to test their concepts and ideas.

Due to the reduced distance between the two arrays and the reduced force on each particle, interference from reflections is more noticeable. This means that the operating range is reduced and only one particle can be controlled. Nevertheless, it is possible to demonstrate that the simulations are correct and that hardware and firmware work properly.

After the tests with the prototype, the hardware was scaled up to the intended array size of 16x16. The larger size reduces the interference problems, allows for better control of the trapped particles, provides much more levitation space and allows to handle multiple particles.

**Result:** During the thesis, a 5x5 prototype array and a larger 16x16 array were designed and manufactured. While the 5x5 prototype array is fully functional, the larger array has a hardware error that prevents its FPGAs from powering up. Therefore, the 16x16 array

is currently not operational, but additional hardware that solves the problem is in progress. Nonetheless, the 5x5 prototype array demonstrates the controlled movement of a single particle.

Levitation Board Prototype (5x5) with levitating particles  
Own presentation

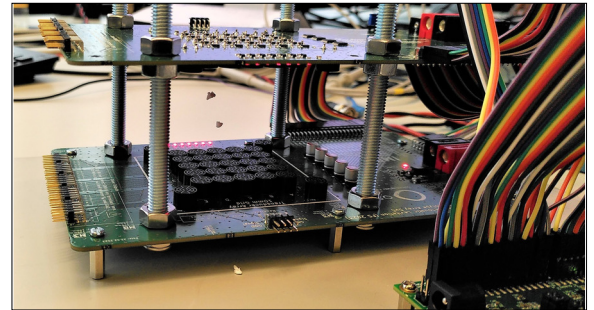

Levitation Board (16x16)  
Own presentation

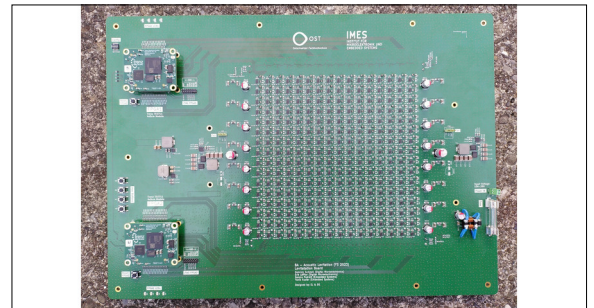

Block diagram of Levitation Board  
Own presentation

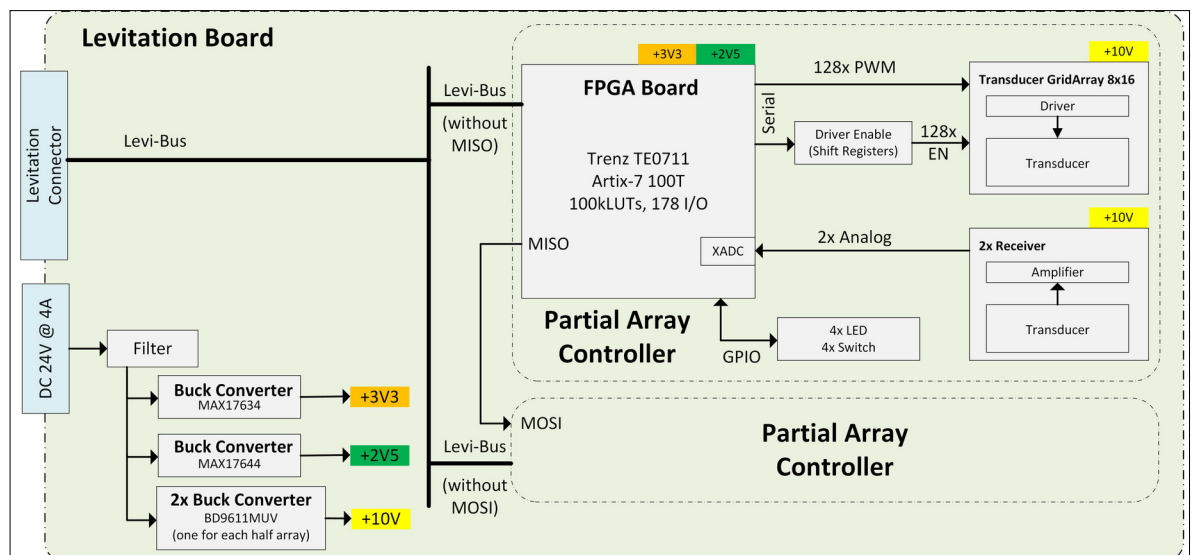

### Advisors

Prof. Dr. Paul Zbinden,  
Dorian Amiet

### Co-Examiner

Robert Reutemann,  
Miomico AG, Zürich,  
ZH

### Subject Area

Microelectronics

### Project Partner

IMES Institut für  
Mikroelektronik und  
Embedded Systems,  
OST - Ostschweizer  
Fachhochschule,  
Rapperswil, SG