

Audio-Beamformer

Highly Directional Steerable Loudspeaker-Array

Graduate



Florian Baumgartner



Thierry Schwaller

Introduction: Naturally, sound waves propagate in an omnidirectional pattern. However, in some cases, a directional pattern would be preferred. In comparison to light or electromagnetic waves, it turns out to be a very difficult task to focus audio waves in a specific direction. The underlying reason for this behavior comes from the physical long wavelength of the audible spectrum. This bachelor's thesis concentrates on how to overcome this effect by using higher frequencies in the ultrasonic spectrum and therefore be able to create a highly directional audio beam. In addition, beam-steering methods are applied to change the direction and focus point by software.

Approach / Technology: In order to achieve a directional sound beam, a linear phased array has been developed, consisting of 19 rows of 8 ultrasonic transducers each. For this, a single PCB, consisting of over 1300 components was specially designed. Two FPGAs modulate the baseband audio signal onto a 40 kHz ultrasonic carrier. First-order Sigma-Delta-Modulators perform the analog conversation in combination with a Class-D amplifier output stage. In addition, each channel can be delayed and attenuated individually. A Raspberry Pi Compute Module 4 is used to apply real-time digital signal processing techniques to further improve the audio quality. Advanced face-detection algorithms are used to locate a target and therefore be able to direct the sound in its direction. As input sources, Bluetooth® and AirPlay® streaming are supported, as well as other input devices, such as USB-Microphones.

Result: The directivity, beam-steering capability, and overall audio quality have been determined in a comprehensive human expertise test. The Audio-Beamformer performs well in all categories and satisfies the project's goals. Especially the range of

up to 50 meters is awe-inspiring. The Audio-Beamformer could lead to a real alternative to conventional loudspeakers with some further improvements.

System Block Diagram
Own presentation

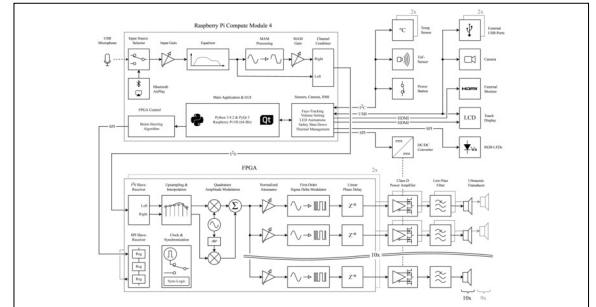

Beam Radiation Pattern
Own presentation

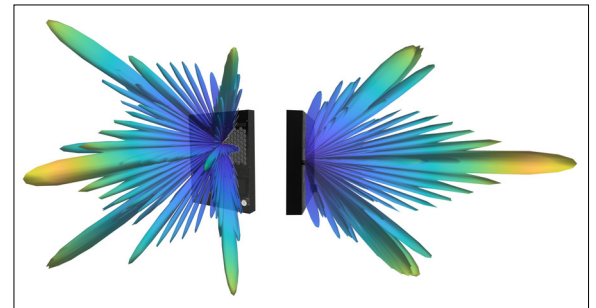

3D-Render of PCB and Case
Own presentation



Advisor

Hannes Badertscher

Co-Examiner

Gabriel Sidler, Teamup Solutions AG, Zürich, ZH

Subject Area

Digital Signal Processing, Embedded Systems

Project Partner

ICAI Interdisciplinary Center for Artificial Intelligence, Rapperswil, SG