

Heat transfer during powder coating

Numerical and experimental investigation and analysis of heat transport during powder coating.

Graduate



Sonja Lanthaler

Introduction: In the powder coating process of steel parts, a layer of powder is first applied to the metal part. Subsequently, the powder is brought to cross-link in a preheated oven for a fixed time, which leads to the formation of the desired coating. The degree of cross-linkage is decisive for the quality of the coating. The required degree of cross-linkage is achieved when the powder has been exposed to a temperature which is precisely specified by the powder manufacturer for a certain duration of time. The degree of cross-linking cannot be determined non-destructively.

In this work, a representative test sample is used to study the influence of the temperature and time on the powder coating process. This test sample is powder coated together with other real-world components. The quality of the coating can thus be determined. For this purpose, it is necessary that the test sample has similar thermal characteristics as compared to the real-world components. The temperature evolution on the surface depends not only on the temperature in the oven, but also on the size, type of metal, shape, surface characteristics, temperature distribution in the oven and other parameters.

Approach: A test sample was produced wherein its thickness can be easily varied. Multiple measurements were conducted in a lab oven, and the surface temperature of the test specimen was recorded in different configurations with respect to its thickness. A FEM model was set up and was calibrated and validated with the help of these measurements and the most important parameters that govern the thermal properties of the test specimen were determined. With these findings, the exact thermal behaviour of the test specimen was compared to three representative real-world components.

Result: This study shows that with the help of this variable test specimen, it is in principle possible to reproduce the coating behaviour of real-world components in a representative manner. This work highlights the conditions in which the test specimen is able to reproduce the surface temperature of the other components.

Prüfkörper
Own presentation

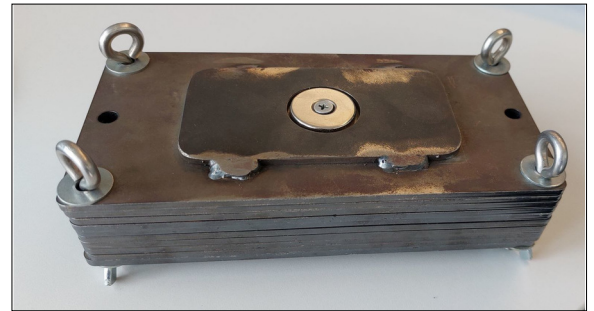

Messaufbau
Own presentation

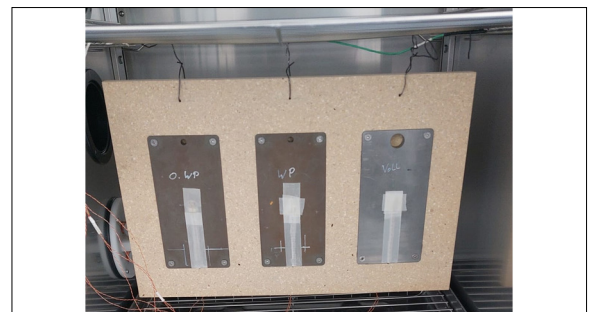

I-Profil
Comsol Multiphysics®

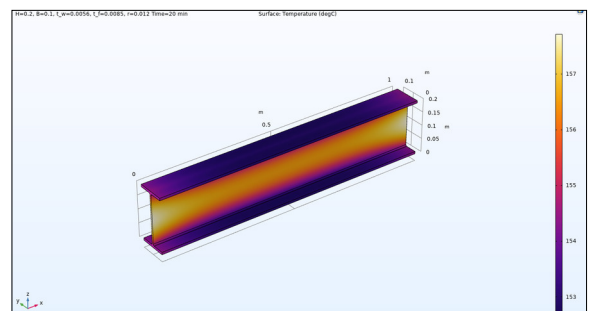

Advisor

Prof. Dr. Michael Schreiner

Co-Examiner

Dr. Gerhard Rizzo

Subject Area

Computational Engineering

Project Partner

Forster Profilsysteme AG, 9320 Arbon, Thurgau