

Localization of Avalanche Transceivers

A Feasibility Study using Kalman Filtering

Graduate



Raphael Unterer



Nicolas Tobler

Introduction: Backcountry skiing and snowshoe hiking are popular winter sports that involve the risk of avalanches. Avalanche transceivers are often used as a fast and reliable tool to locate buried victims. A quick and accurate localization of the victim is crucial to increase the chance of survival, which declines rapidly after a few minutes. The device carried by the victim operates as a sender, whereas the device of the rescuer is in receiving mode. Every second, a 457 kHz radio pulse is emitted which is sensed by the receiver device. Current solutions guide the rescuer to follow the magnetic field lines towards the sender. Once the rescuer is close to the receiver, a sequence of predefined motions needs to be performed to precisely pinpoint the sender device. The objective of this thesis is to achieve a faster and more accurate localization by means of statistical signal processing algorithms.

Approach: Our work introduces two algorithms using extended Kalman filters that differ from the type of used sensors. The physical model of the magnetic field is embodied in the filter to estimate the location and attitude of the sender relative to the receiver device. A first simplified algorithm relies on positional data, which is difficult to obtain on a low power handheld device. The second algorithm is adapted to rely only on already available measurement data of the Mammut Barryvox avalanche receiver device. Both proposed algorithms have been tested extensively in a Monte Carlo simulation environment. The environment simulates the emitted magnetic field, randomized rescuer movement patterns, sensor inaccuracies and noise levels. A hardware demonstrator has been built to test the algorithms in the field using real data from the Barryvox device. The algorithms running on a desktop computer gather sensor data wirelessly from the hardware demonstrator. The instruction outputs are then transmitted to a graphical interface for the rescuer.

Result: Both algorithms perform extremely well in the simulation environment. The sender position estimate gets progressively more accurate during the search phase and omits the need of a pinpoint phase. In the simulated environment, the hardware adapted algorithm is able to accurately locate the victim within 0.3 m horizontal distance median or 0.6 m distance in 90% of all simulation runs. This accuracy is achieved in fewer than 70 simulated seconds. The hardware demonstrator is able to confirm these results to some extent. When following only the instructions on the graphical interface, test subjects have been able to locate the sender in 9 of 10 cases with a mean horizontal distance of 0.6 m. The observed loss in accuracy and robustness may be explained through imperfections of the hardware data stream and difficulties of the hardware integration.

Advisor

Hannes Badertscher

Co-Examiner

Gabriel Sidler, Teamup Solutions AG, Zürich, ZH

Subject Area

Software and Systems

Project Partner

GPV Switzerland SA, Daniel Forrer, Lachen, SZ

Picture showing the augmented receiver device.

Own presentation

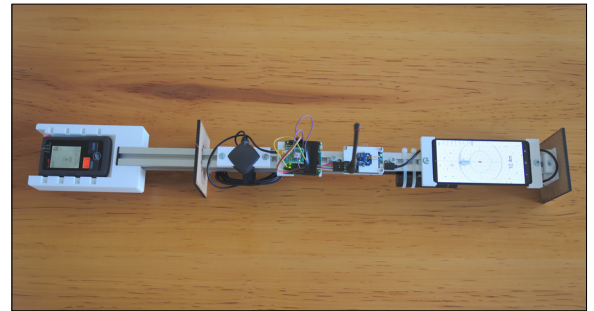

Schematic of the hardware demonstrator.

Own presentation

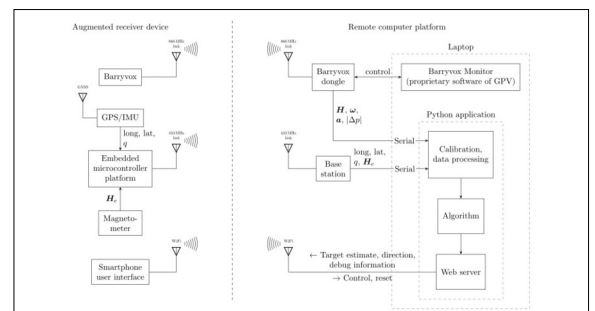

Screenshot of the Simulation.

Own presentation

